



# **HH Spring Invitational 2024**

## **Video Competition Guidelines**



## **Table of Contents**

**Page 2 - Overview**

**Page 3 - How To Enter**

**Page 3 - General Rules**

**Page 4 - Divisions & Division Levels**

**Page 5 - Class Information & Requirements**

**Page 5 - Class #1 - Dressage**

**Page 7 - Class #2 - Equitation Over Fences**

**Page 9 - Class #3 - Working Trail**

**Page 10 - Class #4 - Working Trail UNMOUNTED**

**Page 11 - Compensating Aids**

**Page 12 - Appendix A - Equitation Over Fences (diagram & instructions)**

**Page 13 - Appendix B - Working Trail (diagram & instructions)**



## Overview

Hope Haven Video Competitions provide equestrians of all (dis)abilities and diverse needs an opportunity for competition in the comfort of their home facility and with their familiar mount. A unique advantage of our competitions is that we provide a list of compensating aids allowed to assist individuals with intellectual disabilities as well as physical impairments to reach the highest level of independence.

### Divisions Offered

1. **Open Division** - all ages and abilities.
2. **Special Olympics Division** - competitors must be registered on a Special Olympics Equestrian team that has been recognized by their provincial SO organization.

### Division Levels

There are 6 division levels offered in each of the above divisions. See page 4 for a full description and how to choose what level is appropriate for you or your competitor.

### Classes (Spring 2024)

1. Dressage
2. Equitation Over Fences
3. Working Trail
4. Working Trail UNMOUNTED

### Awards

Ribbons will be presented to the top 8 places in each class under each division level. Results will be finalized by the end of July 2024.



## How To Enter

1. Thoroughly read through this competition package which includes how to determine a competitor's division and division level, class rules, judging considerations, video requirements and class set-up.
2. Solidify with your coach/instructor both the division as well as the division level you will be competing in.
3. Video your class(es) you are entering according to the video guidelines, class set up and pattern requirements provided. Each class must have a separate video.
4. Upload your video(s) onto your YouTube account, format title as follows:  
**Last Name, First Initial - Horse - Class # - Division Level - Month/Year**  
Example: Smith, J - Princess - 3a - BI - 6/23
5. Complete the Online Entry Form; includes waiver and uploading of video links. Entries will be received between **June 17 - 23, 2024**.

## General Rules

1. Must wear an approved safety helmet for all mounted and unmounted classes.
2. Must have boots with heels or enclosed toe stirrups.
3. Halter over bridle or cavesson with fixed ring to be used for supported riders on lead.
4. Competitors must compete in the same division and division level across all entered classes.
5. Different competitors may use the same horse.
6. Assistance (verbal comments, physical prompts, sounds, gestures) from coach, leaders or sidewalkers will result in penalties unless an allowed compensating aid is being utilized (eg. living letters or advanced caller).
7. Compensating aids used must be indicated on competitor entry form in space provided (see allowed compensating aids on page 11).
8. Spotters can be placed strategically for independent riders within the ring.
9. Coaches should not act as leaders or sidewalkers for their own athlete other than acting as an "Advanced Caller" (see compensating aid chart for explanation).



## Divisions

1. Open Division
2. Special Olympics Division

## Division Levels

The athlete's coach is required to determine what division level their athlete falls into and therefore what classes they are appropriate to enter. All decisions on division levels are in good faith and should portray where the rider is the **most independent**. In particular for supported riders, the leaders should be primarily considered a safety, and as much as possible the rider should show their ability to make transitions, steer and sustain paces.

There are 6 division levels: A, BI, BS, CI, CS, UM. See full breakdown in chart below:

Level	Gaits Required	Independent (I) Supported (S)	Other
A	Walk/Trot/Canter	Independent	No assistance
BI	Walk/Trot	Independent	No assistance
BS	Walk/Trot	Supported	Requires a horse leader and/or physical support of 1 or 2 sidewalkers. Has ability to help with transitions and steering, <b>is almost independent at trot.</b>
CI	Walk	Independent	No assistance
CS	Walk	Supported	Requires a horse leader and/or physical support of 1 or 2 sidewalkers.
UM	Unmounted	Independent or supported	May be supported for safety by a long lead on opposite side of participant.



### Classes Offered Per Division Level

Discipline	A Level	BI Level	BS Level	CI Level	CS Level	UM Level
Dressage	Y	Y	N	Y	Y	N
Equitation Over Fences	Y	Y	N	Y	Y	N
Working Trail	Y	Y	Y	Y	Y	N
Working Trail UNMOUNTED	N	N	N	N	N	Y

## Class Information & Requirements

**Class #1a - Dressage - Open Division**

**Class #1b - Dressage - Special Olympics Division**

Division Levels:

- A, BI, CI, CS

Rules

- All dressage tests may be called; movements must only be called twice, any further repetition considered unauthorized assistance. No use of headset unless listed as a compensating aid for hearing impaired.
- Use of voice, including clucking, is a deduction of -2 for the movement where this occurred (unless listed as a compensating aid).
- Trot may be ridden sitting or rising.

Judging

- See test/judges card for full breakdown.

Video Requirements

- Video taken from C.



- If using a phone, make sure to shoot it horizontally.
- Zoom must remain fixed for the entire class, panning of camera allowed to keep rider in centre of the shot.
- Make sure the horse and rider are not lost in the video between H and M.
- Start recording 5 seconds prior to entering at A and 5 seconds after end of test.

#### Set Up

- 40m x 20m
- All letters marked at correct locations

#### Tests

- Both Open Division and Special Olympics Division will use the same EC tests indicated below.

Please refer to your division level below and click on the corresponding test:

#### Division Level A

[EC Introductory Test C](#)

#### Division Level BI & BS

[EC Introductory Test B](#)

#### Division Level CI & CS

[EC Para Walk Test 2](#)



## **Class #2a - Equitation Over Fences - Open Division**

## **Class #2b - Equitation Over Fences - Special Olympics Division**

Due to the nature of video competitions, this equitation class is limited to 6 fences with basic set up requirements in order to be accessible to all centres.

### **Division Level Requirements**

- CS & CI Levels - Walk course of 6 ground poles
- BI Level - Trot course of 6 fences, 30cm ground pole at X)
- A Level - Trot and Canter a course of 6 fences, 60cm (ground pole at X)

### **Rules**

- Wraps and boots on horses legs are permitted and advised.
- No whips or crops unless it's an approved compensating aid (see page 11).
- No spurs.

### **Judging**

- Each pole/fence is marked out of 10 points.
- Emphasis on effectiveness of rider, not quality of horse.
- Scoring based on accuracy of course, correct approach, straightness, corners, position over jump (2-point), and horse accepting quiet aids.
- Courtesy circles recommended for trot and canter levels.
- Faults:
  - Knocking down obstacle (2 faults)
  - Knocking ground pole (2 faults)
  - First refusal (3 faults)
  - Second refusal (3 faults)
  - Third refusal (elimination, may finish course)
  - Off course (elimination, may finish course)
- General Deductions:
  - BI riders - if poles are moved to ground = 15 point deduction overall
  - A & BI riders - if jumps are moved down to x's = 10 point deduction
  - No attempt at 2-point position = 5 point deduction per fence
  - 3 strides over allotted gait for that division = 5 point deduction per occurrence
  - Use of a crop or whip (for different reasons than an allowable compensating aid) = 10 point deduction

### **Video Requirements**





- Video taken from A.
- If using a phone, make sure to shoot it horizontally.
- Zoom must remain fixed for the entire class, panning of camera allowed to keep rider in centre of the shot.
- Start recording at least 5-10 sec before fence 1, stopping 5-10 sec past fence 6 (enough to see approach, finish, courtesy circles).

#### Class Set Up

- Refer to **Appendix A - Equitation Over Fences** for diagram & instructions
- Approx 25m x 45m required, fenced or enclosed arena
- Fences to be set at the following verticals for each division:
  - A = 60cm (ground pole at X)
  - BI = 30cm (ground pole at X)
  - CI & CS = ground poles
- Note - in General Deduction instructions above, fences for Level A may be moved down to x's and Level BI to x's or ground poles however they will be given appropriate deductions.
- **\*\*Don't forget to read the course instructions\*\***



## **Class #3a - Working Trail - Open Division**

## **Class #3b - Working Trail - Special Olympics Division**

### **Division Levels:**

- A, BI, BS, CI, CS

### **Rules**

- Wraps and boots on horses legs are permitted and advised.
- No whips or crops unless it's an appropriate compensating aid (see page 11).
- No spurs.

### **Judging**

- Rider's ability to guide the horse through a designated course. Credits given to horses negotiating the obstacles correctly while responding to the rider's cues.
- Errors:
  - Excessive amounts of time approaching or at an obstacle will be penalized.
  - If a horse balks or avoids an element (with or without leader) it's a -2 deduction. They are allowed 1 more attempt and if missed it's another -2 and then they must move on.
  - Off course = elimination but may finish course
    - Taking obstacle in wrong direction or from wrong side
    - Taking obstacle in a different manner than described in pattern
    - Skipping an obstacle
    - Negotiating obstacles in wrong sequence
  - Use of a crop or whip (for different reasons than an allowable compensating aid) = 10 point deduction

### **Video Requirements**

- Video taken from A. (start is in corner at C end)
- If using a phone, make sure to shoot it horizontally.
- Zoom must remain fixed for the entire class, panning of camera allowed to keep rider in centre of the shot.
- Start recording just before entering at A, stop recording after exiting at A.

### **Class Set Up**

- Minimum 25m x 45m required, fenced or enclosed arena
- Equipment Required:
  - Mailbox - Small object placed in mailbox
  - 1 barrel



- 5 pylons for weaving line
- 1 pylon for left turn
- 2 cavalettis or raised poles for narrow passage
- Bridge
- 5 poles in arc
- 4 poles to form a box

Diagrams

**Appendix B - Working Trail Course & Instructions**

**Class #4a - Working Trail UNMOUNTED - Open Division**

**Class #4b - Working Trail UNMOUNTED - Special Olympics Division**

Follow same guidelines as Class #3. See Appendix B.



## Compensating Aids

All aids listed below are for use in all classes as deemed appropriate.

### Intellectual Disabilities

<b>Memory</b>	- Everyone with an ID allowed a caller - Numbering of jumps or elements
<b>Spatial Awareness (unmarked transition points (eg. x), lines, circles, corners)</b>	Pylons, shavings, poles (minimal)
<b>Left-Right Confusion</b>	Bracelets on wrists, coloured ribbons on reins
<b>Obtaining Correct Rein Length</b>	Rainbow reins or looped reins
<b>Illiterate with letters</b>	Animal pictures or colours at letters
<b>Requires specific, 1 step instructions (unable to complete more complex instruction such as "20m circle at A")</b>	"Advanced caller" - coach walking near rider to call 1 step instructions such as transitions, turns and other physical steps needed to complete task. (eg. turn left, halt, walk on, 2-point)

### Physical Disabilities

<b>Visually impaired</b>	Living letters or elements
<b>Hearing Impaired</b>	- Cue cards in place of verbal calling: (1=walk 2=sitting trot 3=posting trot 4=canter 0=reverse stop sign=halt) - Headset for caller - ASL interpreter for caller
<b>Limited use of legs</b>	- 1 or 2 Dressage whips - Use of voice
<b>Difficulty maintaining grip on reins</b>	Looped, rubber, ladder
<b>Positioning needs or safety of hand hold</b>	Pad and surcingle options
<b>Balance deficits</b>	- Hard hand hold - Use of voice - Sticky seat saver/gel pad - Hands off spotter follow as sidewalker
<b>Sensory impairment in saddle region</b>	Seat saver



## Appendix A Equitation Over Fences

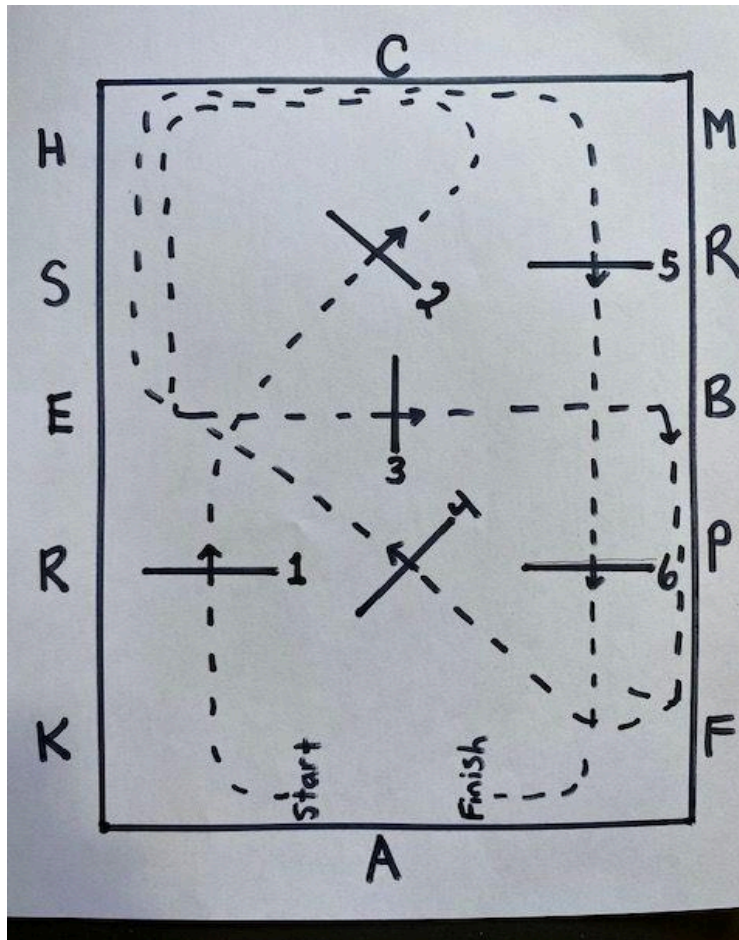

### Level CI/CS Instructions

- Walk entire course of ground poles
- Hold 2-point position from pole 5 right through pole 6

### Level BI Instructions

- Trot entire course of verticals (30cm), ground pole at X
- Sit trot from E to B
- Hold 2-point position from jump 5 through jump 6

### Level A

- Start course at a trot
- Sit trot from E to B
- After jump 4 continue in a canter
- Continue in canter through Finish



## Appendix B Working Trail

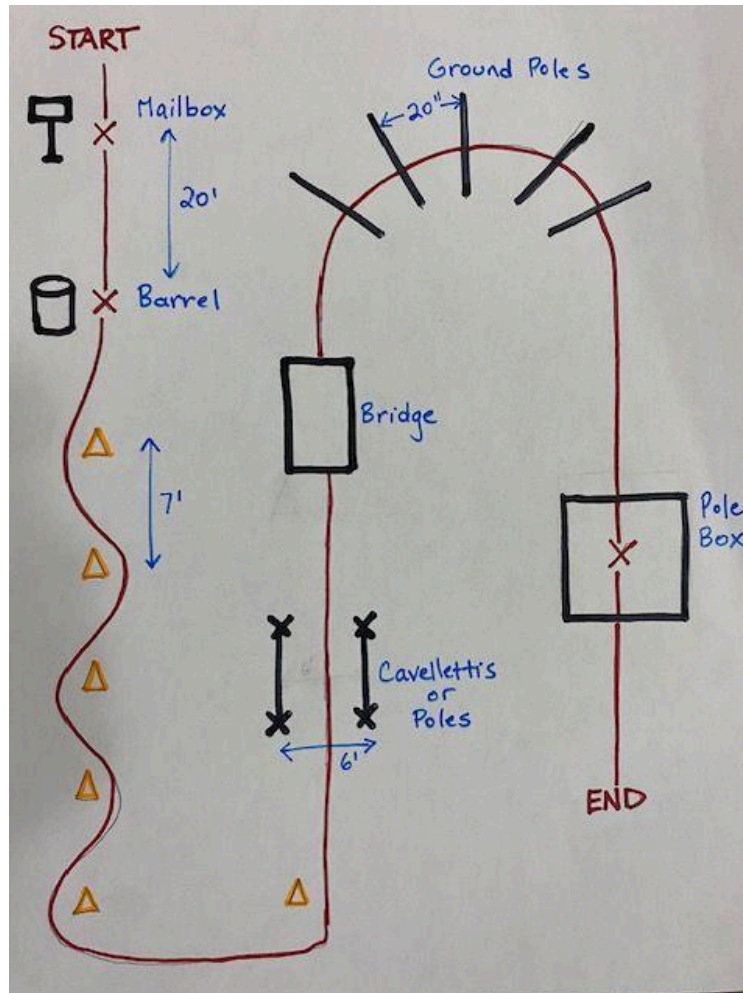

**NOTE - Set up is the same but instructions are different for each level.**

### Level CI/CS/UM

1. Walk to mailbox, halt and retrieve a small object
2. Walk to barrel, halt and place object on the barrel
3. Weave through 5 pylons at a walk
4. Turn left at pylon, continue on a straight line. Walk between 2 cavalettis
5. Walk over bridge
6. Continue at a walk through centre of curved pole line
7. Enter box and halt in middle of box for 5 seconds
8. Continue to End



### **Level BS/BI**

1. Walk to mailbox, halt and retrieve a small object
2. Walk to barrel, halt and place object on the barrel
3. Weave through 5 pylons at a walk
4. Turn left at pylon, pick up trot continuing between 2 cavalettis
5. Transition to walk immediately after cavalettis, walk over bridge
6. Immediately after bridge pick up trot and continue through centre of curved pole line
7. After pole line, transition to walk, enter box and halt in middle of box for 5 seconds
8. Continue to End

### **Level A**

1. Walk to mailbox, halt and retrieve a small object
2. Walk to barrel, halt and place object on the barrel
3. Pick up a trot and weave through 5 pylons
4. Turn left at pylon, continuing in a trot between 2 cavalettis
5. Transition to walk immediately after cavalettis, walk over bridge
6. Immediately after bridge pick up trot and continue through centre of curved pole line
7. After pole line, transition to walk, enter box and halt in middle of box for 5 seconds
8. Continue to End